

AllStar & Echolink Project

What This Presentation Covers

- Methods to link systems
- Our Local Project
- How to use it
 - From a PC or Smartphone
 - From your Radio
- How to Roll Your Own

Methods to Link Ham Systems

Drilling Into AllStar

Types of Ham Radio Linking for Voice

- Fully Digital
 - Digitized audio end-to-end - from your microphone to their speaker
 - Requires new radios & repeaters, all require some proprietary, closed components
 - Examples: DMR, DSTAR, System Fusion
- Analog over IP
 - Analog RF to repeater - digital IP between repeaters, simplex nodes, computers
 - Overlays nicely on top of existing radios and repeaters
 - Can add Internet connections from PCs, smartphones
 - Examples: IRLP, Echolink, AllStar
- Analog over analog radio
 - Analog (usually FM) end-to-end
 - Limited distance, can lose quality with each hop
 - Examples: FM radio links, split-site repeaters

Ham Analog Over IP Voice Linking Systems

- IRLP
 - Radio to Radio only (by design) - no smartphone/PC connectivity
 - Run by one guy
- Echolink (<http://echolink.org>)
 - Radio/Smartphone/PC to Radio/Smartphone/PC
 - Good (but not great) voice quality
 - Easiest Smartphone option
 - Has some network limitations
 - Used to require Windows PC at repeater
 - Now can do with Raspberry PI and Linux (with some limitations)
- AllStar (<http://allstarlink.org>)
 - Radio/Smartphone/PC to Radio/Smartphone/PC
 - Smart Phone and PC support works, but is a little “rough”
 - Great, crystal clear voice quality (as good as the radio/repeater is)
 - Best repeater-to-repeater options
 - Very flexible network options
 - Can function without the Internet (using private networks)

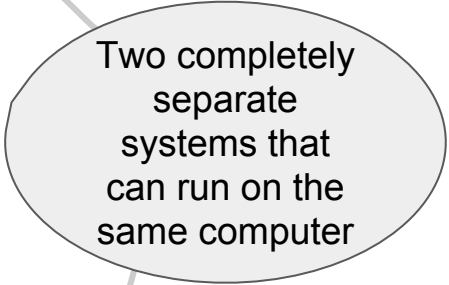

Two completely separate systems that can run on the same computer

Allstar Software - some details

- Based on Asterisk - a free, open source Linux based PBX phone system
 - Asterisk used in business to handle many phone extensions, voicemail, auto-attendant, etc
 - Adapted a little to connect radio systems
 - Carries voice, and PTT, COS, other radio-specific information
- App runs on Linux called “app_rpt” that handles Allstar connections between repeaters, simplex nodes, computers
- Can run on any Linux computer (PC, laptop, Raspberry PI, etc)
- Ready made Linux installation called “Dial”
 - Install, configure, tweak, and go

More About AllStar

- More than 1500 nodes online across the world as of Feb 2016
- Including:
 - the statewide W3WAN Wide Area Network in PA
 - several other large multi-state systems across the U.S.
- Since it's a completely open standard - hams are experimenting
 - Bridges to DMR digital talkgroups, DSTAR reflectors, Echolink
 - Lots of small simplex nodes at people's houses
 - You can make your own (later in these slides)
 - Some huge statewide and worldwide networks
 - Some small scale networks with 2-3 repeaters linked
 - Some systems are interconnected full time, some on demand

How AllStar/Echolink work

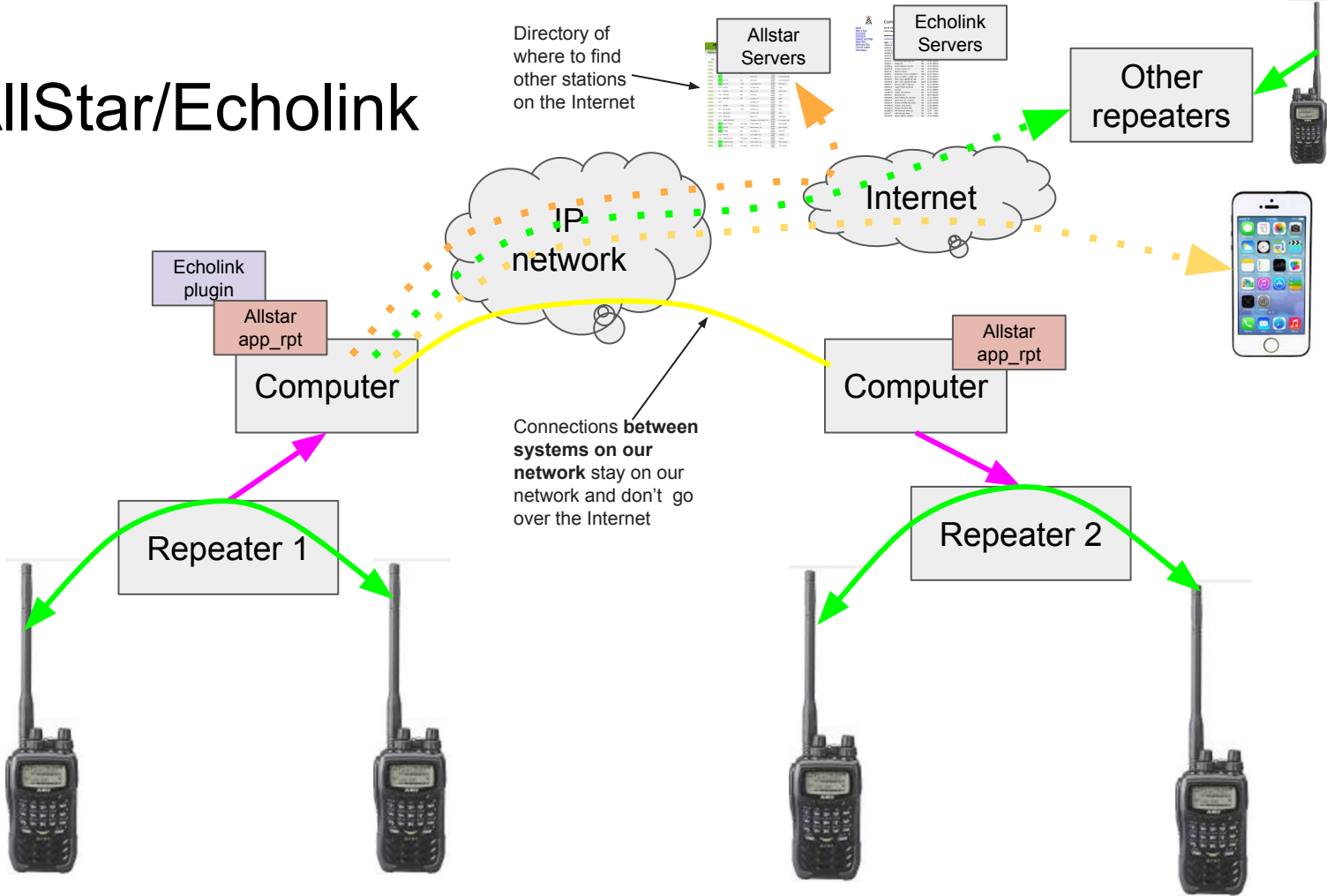

Example AllStar Node Map

on <http://AllStarLink.org>

Shows connections to the W3WAN Wide Area Network that covers most of Pennsylvania

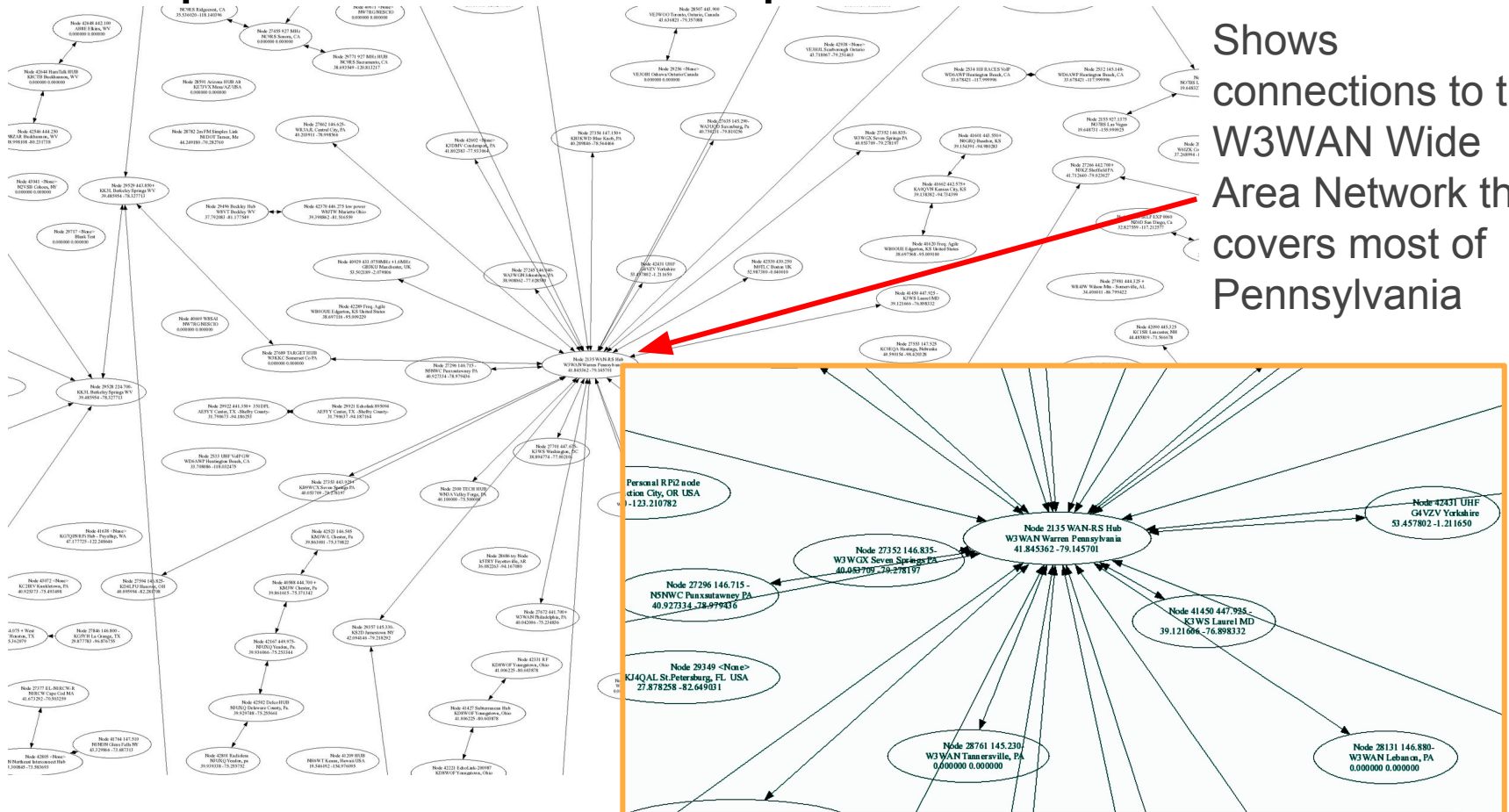

Summary of Linking Modes

- We're focusing on linking **analog** systems together
 - Nothing wrong with digital modes, just not what we're doing
- AllStar is great for linking repeaters, networks, and RF users together
- AllStar from a Smart Phone or PC is rough around the edges
- Echolink has some drawbacks
 - but... Echolink is easiest to use from Smart Phones and PCs so we can't ignore it

Our Local Project

What, Who, and Why of our local project

- What:
 - Establish IP data networking between several area repeaters
 - Connect it all to the Internet
 - Use it for some new and really cool connectivity options, like AllStar
- Who:
 - Corroboration between
 - N8XPK
 - SARA (Silvercreek ARA) (<http://w8wky.org>)
 - Wayne Technical Fanatics (<http://ke8abm.club>)
 - Others including WA8DBW
- Why:
 - Because we can, and it's cool
 - It enhances our ability to communicate
 - FCC wants hams to “contribute to the advancement of the radio art”

Our Connectivity Philosophy for the network

User Connectivity

- Primary user connectivity via RF
- Secondary via Echolink
 - For easy smartphone support
 - Requires one routable Internet address (broadband connection) per node
 - Limited resource, costs money for more Echolink Nodes
- With Broadcastify for dessert
 - So anyone can listen in with or without a license

Repeater to Repeater

- Primary inter-connectivity via AllStar
 - To serve RF users (after all, this is Ham **RADIO**)
 - Works on our local network, or via the Internet
 - Very flexible with great network compatibility
 - Best for repeater-to-repeater linking
 - Superior audio quality
- Secondary via Echolink
 - Only from Echolink enabled repeaters
 - Network complications limit this

Our Repeater Configuration

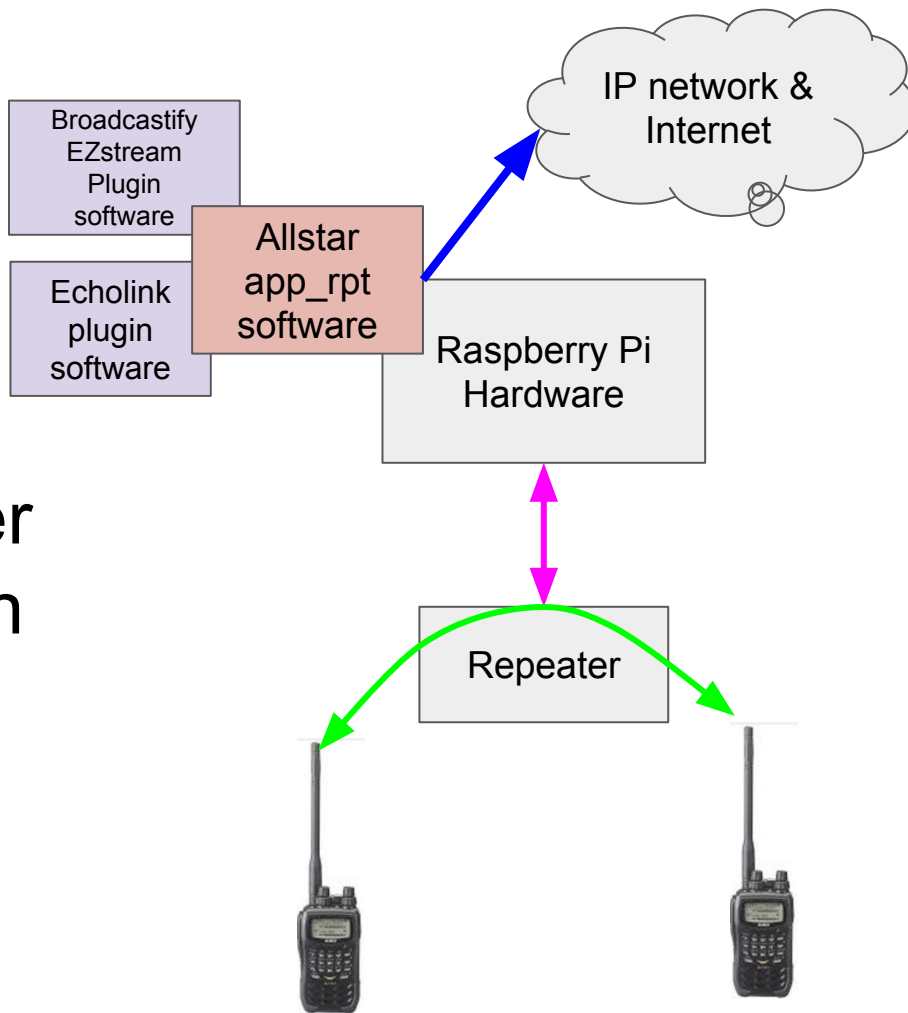

Transporting the signal

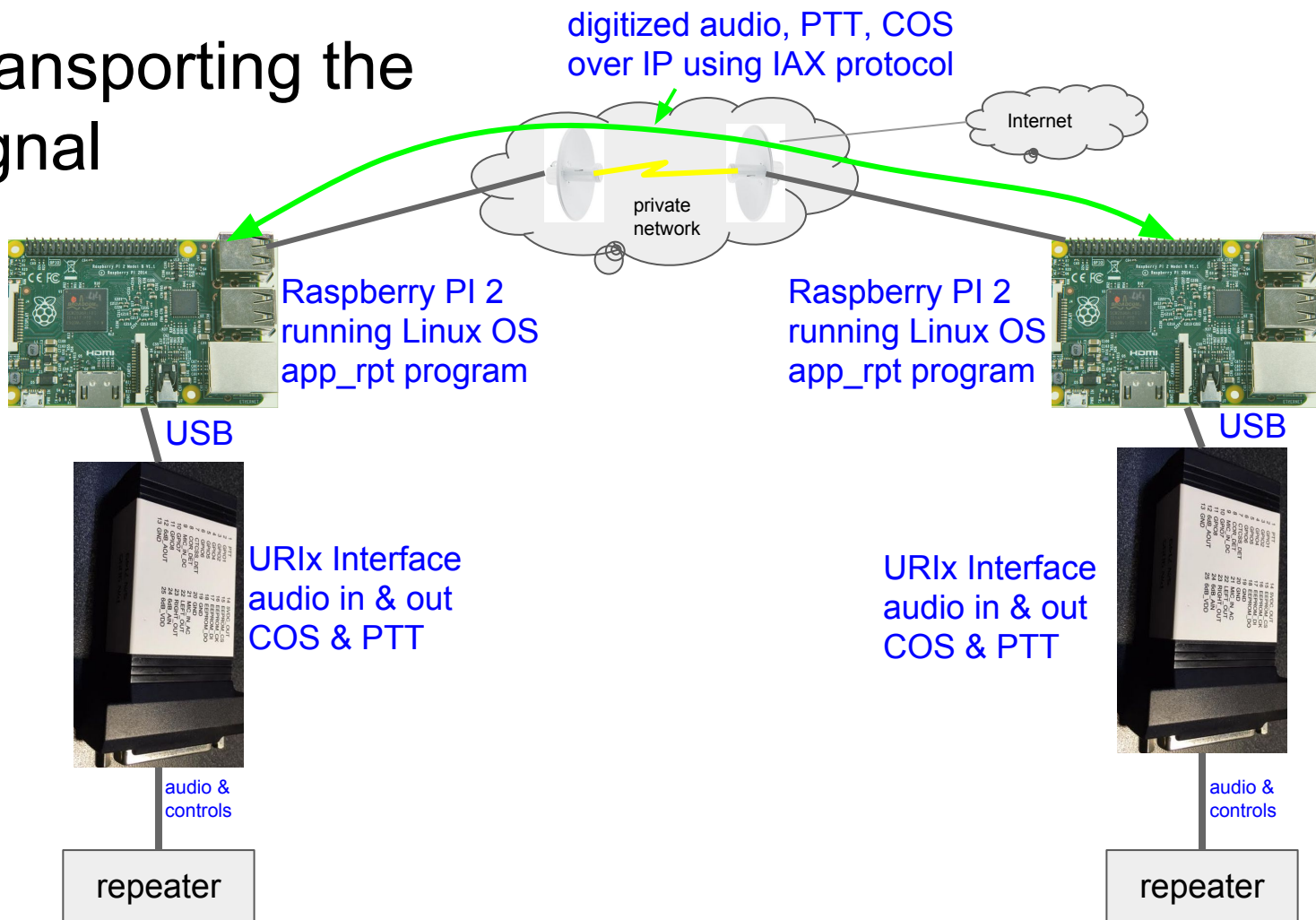

What We're Doing

The end game by summer 2016

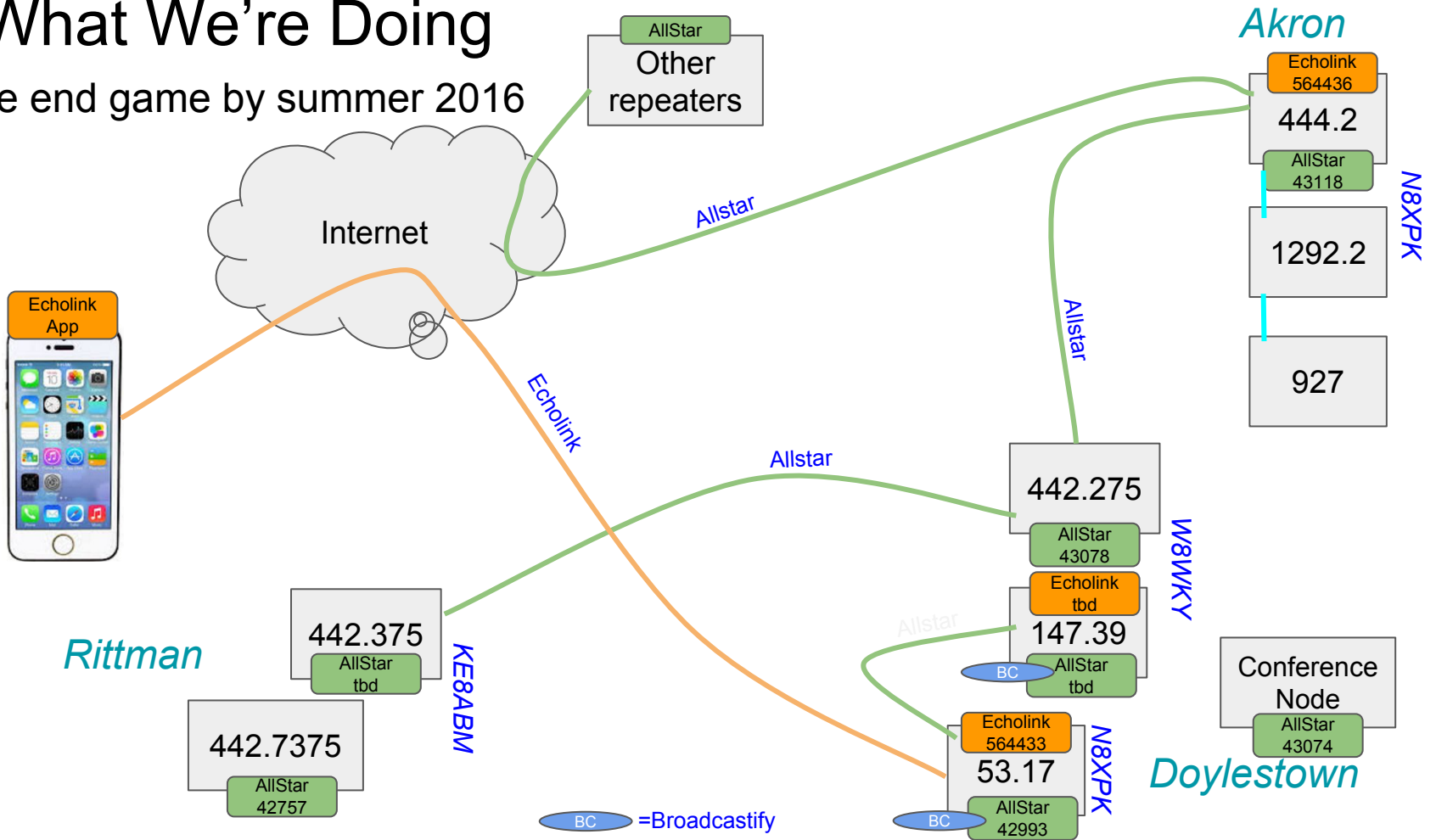

Where We're Doing It

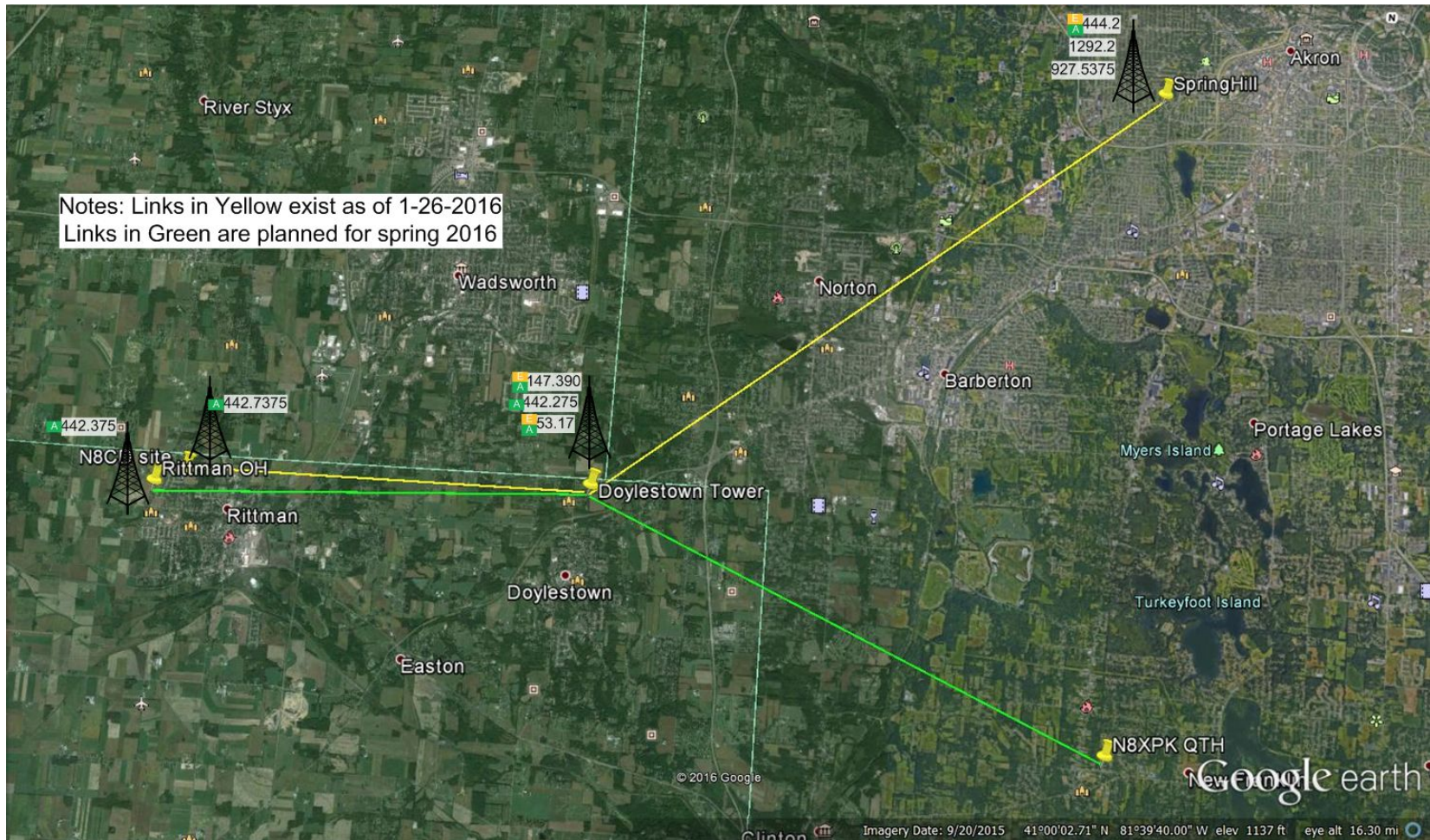

Nodes, Capabilities, and Schedule in Local Network

Callsign	Frequency / CTCSS	AllStar Node	EchoLink Node	Broad-castify	Supported Usage	QTH - Coverage
N8XPK-R	53.170 / 107.2 Hz **	42993	564433	Yes	Inbound AllStar & Echolink only	Doylestown OH - 60 mile radius
N8XPK-L	444.200 / 131.8Hz	43118	564436		Inbound AllStar & Echolink only	Akron OH - 30 mile radius
W8WKY-L	442.275 / 110.9Hz	43078	no		Inbound and Outbound AllStar	Doylestown OH - 20 mile radius
W8WKY-R	147.390 / 114.8Hz	spring '16	spring '16	spring '16	Inbound AllStar & Echolink only	Doylestown OH - 40 mile radius
KE8ABM	442.375 / 100.0Hz	spring '16	no		Inbound and Outbound AllStar	Rittman OH - 15 mile radius
KE8ABM	442.7375 / 131.8Hz	42757	no		Inbound and Outbound AllStar	Rittman OH (low profile test system) 5 mile radius
Conference Hub	n/a	43074	n/a		Inbound AllStar	Doylestown OH - no radio - a meeting "room"

** 4 receiver sites (transmit one of these PL (CTCSS) tones to select which receiver you go through): 107.2Hz Akron, 110.9Hz Loudonville, 123.0Hz Stone Creek, and 136.5Hz Richfield. The repeater's transmitter always transmits 107.2Hz PL

How To Use It

How To Use it - Basic Guidelines (1)

- Remember to ID properly
 - Both on the radio, the computer and the phone
 - You're still going on the air even if you're on the computer
 - When you are entering link and unlink commands, remember you could be transmitting on remote systems
 - Good to give your callsign before each DTMF command to ensure proper ID
- There is a delay between the radio and computer
 - about 1 second (leave some space between transmissions)
- Courtesy tones will change when link status changes
- If you use your radio to initiate a link to a remote node or hub
 - Please listen while it is linked
 - Disconnect when you're done (especially if it's a busy node)

How To Use it - Basic Guidelines (2)

- When linking outbound to outside systems, please use these UHF repeaters
 - 442.275 (online now)
 - 442.375 (coming on the network spring 2016)
 - Gives us all time to work through the processes
- Inbound Echolink and AllStar connections welcomed on:
 - 147.39 (coming on the network spring 2016)
 - 53.17 (online now)
 - 444.2 (online now)
 - Repeater Control Ops may also link these from time to time
 - Feel free to use them when they're already linked or when outsiders have linked up

How To Use it (details on following slides)

- From the radio (best experience)
 - Talk through a repeater that is already linked by someone else
 - Tell the repeater to connect to another system
 - via DTMF tones (give your callsign before entering commands)
- For convenience
 - From a PC
 - AllStar WebTransceiver
 - Echolink Client
 - From a Smartphone
 - Echolink Client
 - Broadcastify website or client for listen-only

How To Use It From a PC or Smart Phone

A Word About License Verification

- Any ham can use radio to radio links (no validation required)
- To connect using a Smartphone or PC - must get license validated by the AllStar and Echolink teams
 - keeps non-hams from coming out on radio links they aren't allowed on
- What is required
 - Echolink
 - Sign up for an account <http://echolink.org>
 - License validated by Echolink team (upload official copy to them for approval)
 - Allstar
 - Sign up for an account (<https://www.allstarlink.org>)
 - U.S. hams - Allstar team looks you up on QRZ

How To Use it AllStar WebTransceiver from a PC

- AllStar Web Transceiver
- Based on Java (unfortunately)
- It is difficult to get running
- Install Latest Java from java.com
- Go to AllStarLink.org
- Click WebTransceiver
- Launch WebTransceiver

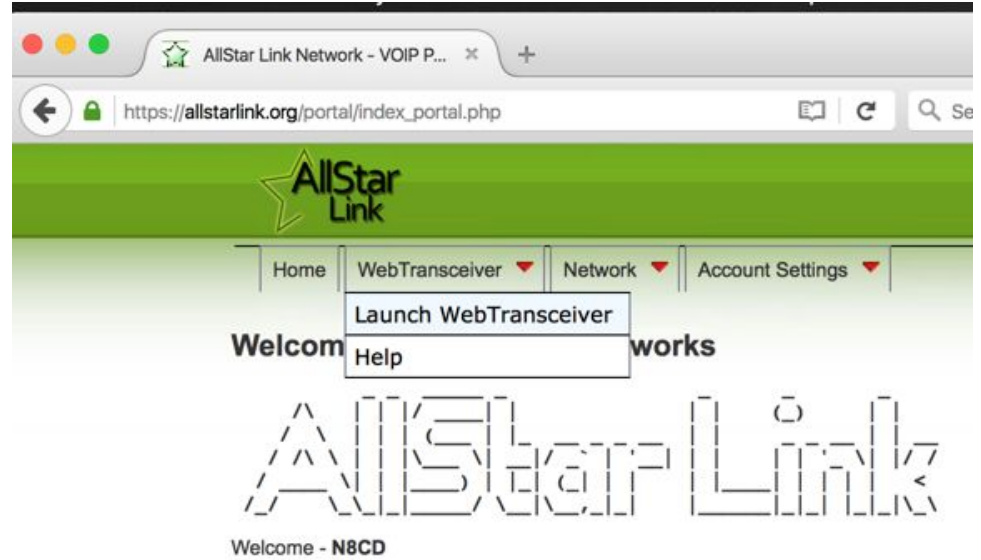

AllStar WebTransceiver

Find the node you want to connect to

Click the Node Number

You will see several security warnings from Java and other things you must accept.

If you get through all that...

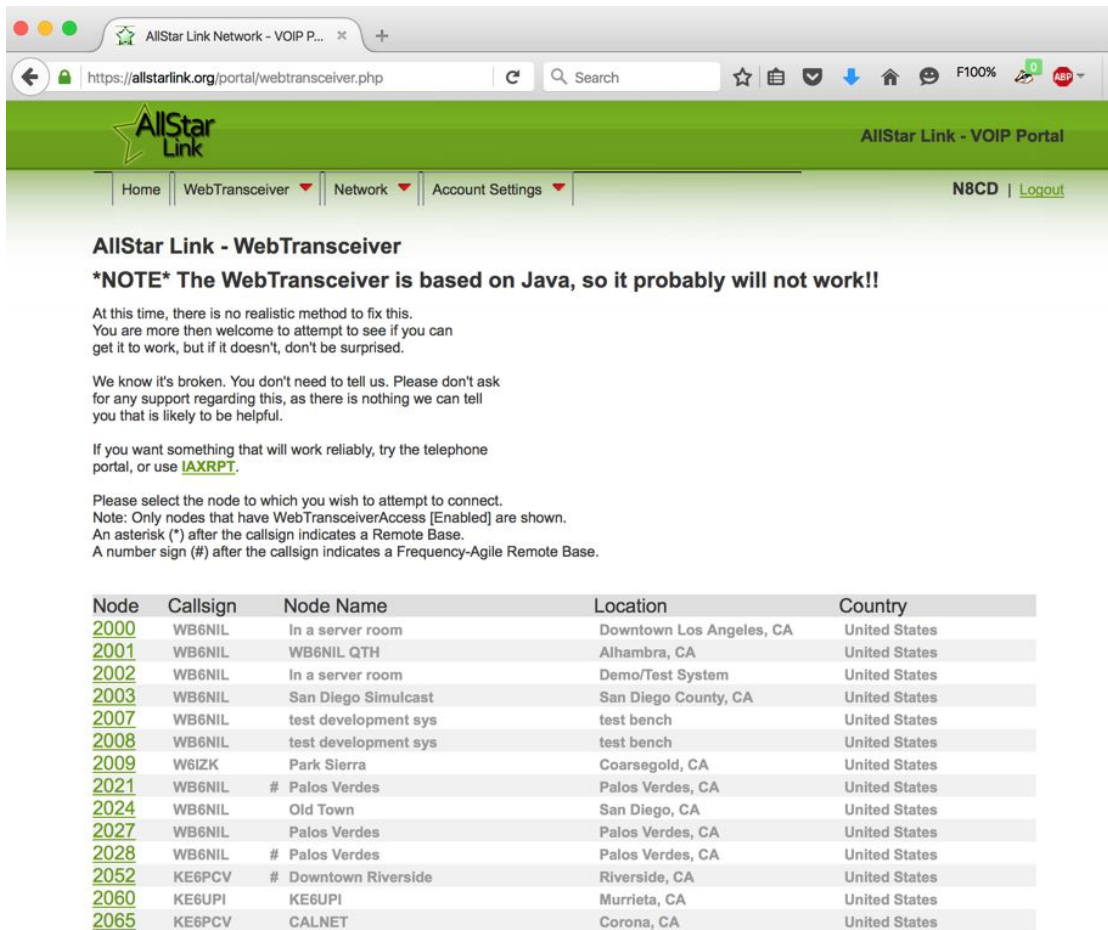

The screenshot shows a web browser window with the URL <https://allstarlink.org/portal/webtransceiver.php>. The page title is "AllStar Link - WebTransceiver". A prominent note states: "*NOTE* The WebTransceiver is based on Java, so it probably will not work!!". Below this, there is a warning that the service is broken and no support is available. A table of nodes is provided for selection, with columns for Node, Callsign, Node Name, Location, and Country. The nodes listed include various locations such as Downtown Los Angeles, Alhambra, San Diego County, Palos Verdes, and Riverside.

Node	Callsign	Node Name	Location	Country
2000	WB6NIL	In a server room	Downtown Los Angeles, CA	United States
2001	WB6NIL	WB6NIL QTH	Alhambra, CA	United States
2002	WB6NIL	In a server room	Demo/Test System	United States
2003	WB6NIL	San Diego Simulcast	San Diego County, CA	United States
2007	WB6NIL	test development sys	test bench	United States
2008	WB6NIL	test development sys	test bench	United States
2009	W6IZK	Park Sierra	Coarsegold, CA	United States
2021	WB6NIL	# Palos Verdes	Palos Verdes, CA	United States
2024	WB6NIL	Old Town	San Diego, CA	United States
2027	WB6NIL	Palos Verdes	Palos Verdes, CA	United States
2028	WB6NIL	# Palos Verdes	Palos Verdes, CA	United States
2052	KE6PCV	# Downtown Riverside	Riverside, CA	United States
2060	KE6UPI	KE6UPI	Murrieta, CA	United States
2065	KE6PCV	CALNET	Corona, CA	United States

AllStar WebTransceiver

Click Key to transmit

Unkey to receive

Callsign	N8XPK-R
Location	Doylestown OH
Country	United States
Affiliation	N8XPK Wide Area 6m Repeater
Site Name	Doylestown 53.17
Timezone	GMT -5
Frequency	53.170 -
Tone	107.2

Key (Transmit) Disconnect

1	2	3
4	5	6
7	8	9
*	0	#

Sent And Received Messages

Node Connection Status
Portal Users:
N8CD

Enter Message Here (Press <Enter> to send)

Echolink specifics

- Echolink servers (the Internet) required to find each other
 - No Internet, No Echolink
- Originally a Windows-only app for both users and repeaters
- Officially, supported on Windows
- Compatible apps available on Apple iOS, and Android
- Un-official (mostly) compatible apps can run on Mac, Linux
- We're using an "unofficial" plugin to connect to Echolink
 - What you keep
 - Ability to connect to & from other Echolink-only repeaters and users
 - What you lose
 - The real callsign and node numbers of connecting users

Echolink from a PC

- Windows program
- Get your call validated
- Sign in to the app
- Use it

The screenshot shows the EchoLink - N8CD application window. The title bar reads "EchoLink - N8CD". The menu bar includes "File", "Edit", "Station", "Tools", "View", and "Help". The toolbar contains various icons for station management and communication. Below the toolbar, a status bar indicates "6,067 stations on naeast.echolink.org [15% are busy]". The main area displays a table of stations with columns for Station, Stat, Time, Location, and Node.

Station	Stat	Time	Location	Node
AE6TV-R	On	13:14	Grand Terrace	246180
AE7RZ-R	On	14:32	Linked to W7GAA repe (1)	897828
AE7SM-R	On	14:31	Montana, DN58en	697401
AF5XP-R	On	15:14	Sulphur,La 444.625+ [0/20]	367505
AF6VU-R	On	17:04	Santa Barbara, CA / Allstar	889535
AF7DX-R	On	12:09	Private Conference	9865
AF7UM-R	On	13:36	Seaside STARS 49 Rptr	532135
AG5BB-R	On	14:36	Hobbs,NM	281850
AG6AU-R	On	13:14	In Conference IRLP 3598	668182
AG6IF-R	On	12:28	Link W6GTR Temecula CA	755176
AH2S-R	On	13:14	SLC, UT [0/5]	909380
AH6GR-R	On	11:14	Maui Hawaii [0/20]	151967
AH6LE-R	On	13:14	In Conference IRLP 9790	303161
AI6BX-R	On	13:14	Redlands, CA	275520
AJ4FR-R	On	16:32	Durbin, FL	422890
AJ4RC-R	On	16:14	Roanoke Rapids, NC	661107
AJ7JA-R	On	13:14	Seattle	167656
AK3E-R	On	16:35	Rawlinsville, PA	644720
AK3J-R	On	16:34	Somerset, PA K3SMT-R	506066
AK3ML-R	On	16:36	Cudjoe Key, FL	220314
AK4B-R	On	15:26	Cullman, AL	873123

At the bottom of the window, there are tabs for "Index View" and "Explorer View". The status bar at the very bottom displays "[Not in QSO]".

How To Use Echolink From a Smartphone

- iPhone and Android apps
- Get your call validated
- Sign in to the app
- Use it

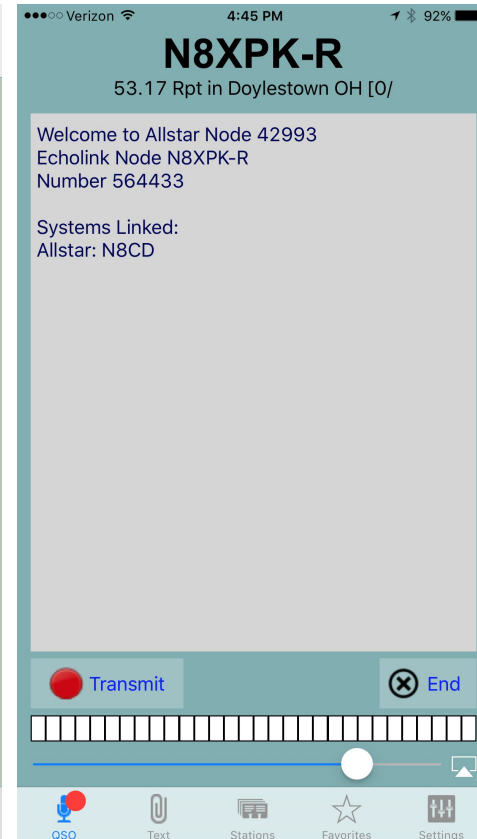
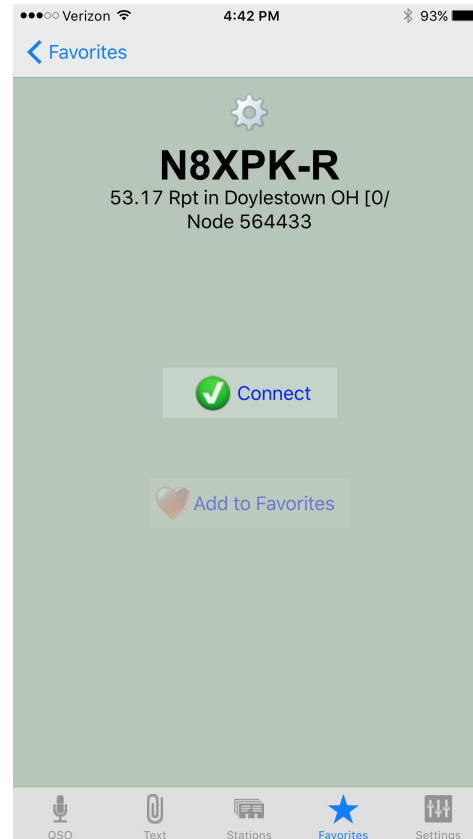
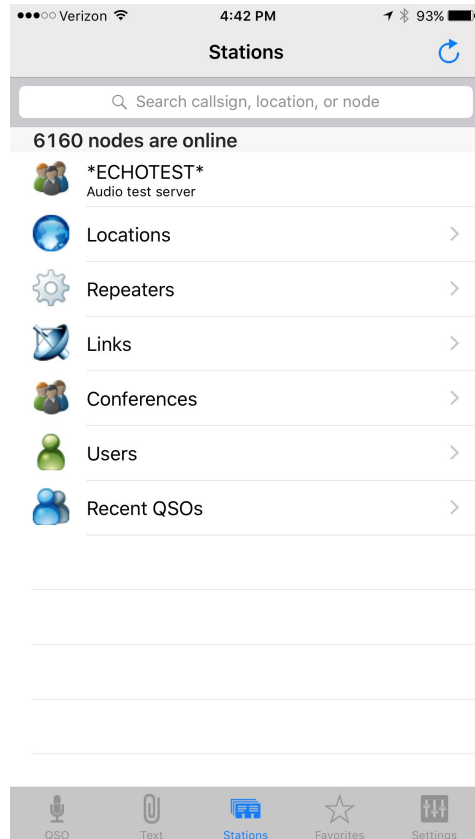

Broadcastify

- A way to listen to some of the repeaters on the network
 - 147.39 (coming on the network spring 2016)
 - 53.17 (online now)
- Go to <http://radioreference.com>
- Click Live Audio... then Live Audio Home
- Drill into map for Ohio... then Wayne County
- Find 53.17 (online now) or 147.39 (Spring 2016)
- Click Listen
 - It's a little quirky - may not be online 24x7
 - May have to choose HTML5 Web Player, Flash Web Player, others
- There are also Broadcastify apps for iPhone and Android in the app store

How To Use It From a Radio

How To Use it From A Radio

- **Use these UHF Repeaters to link outbound to other systems:**
 - 442.275 (online now)
 - 442.375 (coming on the network spring 2016)
 - AllStar nodes: Feel free to connect inbound and outbound from the UHF repeaters
 - Cannot do outbound links to Echolink-only repeaters from these repeaters
 - May expand later - gives us all time to work through the processes
- User initiated outbound linking is not supported at this time on these repeaters:
 - 147.39 (coming on the network spring 2016)
 - 53.17 (online now)
 - 444.2 (coming on the network spring 2016)
 - Feel free to link to these repeaters from the outside
 - If you hear a linked station on these repeaters, feel free to jump in

How To Use it From A Radio - Guidelines

- If you use your radio to initiate a link to a remote node or hub
 - Please keep an ear on things while you have it linked
 - Disconnect when you're done if you initiated it (especially if it's a busy node)
- Try to maintain a good signal into the repeater
 - 100mw on an HT / rubber duck inside your car is not your friend
- Use courteous radio and linking practices
 - Listen
 - Don't do a "drive by"
 - Don't Link, interrupt a QSO in progress, Unlink
 - If you're not sure what you're linking into:
 - Link in Receive Only Mode first (* 2) to hear what's on the remote
 - Then change to transceive mode (* 3) when you want to join in
 - More in following slides

First - What are all these numbers?

- Every AllStar repeater, simplex node, and conference hub is assigned a node number
- From a PC or Smartphone, you normally don't need them
 - You can search lists and connect by callsign from computers
- To connect from another repeater or radio, you need to enter the node number on your DTMF pad
 - since you can't browse for a callsign from your radio
- Where do I get the Node Numbers?
 - AllStar Node Numbers: <http://stats.allstarlink.org/>
 - EchoLink Node Numbers: <http://echolink.org/logins.jsp>

User DTMF Commands and Connection Examples

- Common DTMF commands from a radio through a repeater **on our UHF machines**
 - Connect to a node Receive Only: *** 2 [node number]**
 - Connect to a node Transceive: *** 3 [node number]**
 - Read back list of what is connected: *** 7 0**
 - Unlink everything: *** 7 1**
 - Unlink a specific node: *** 1 [node number]**
 - Give the time *** 8 1**
- Example 1:
 - You are on a radio through the 442.275 repeater, node 43078
 - You wish to connect to the 53.17 repeater, node 42993
 - Key up, **say your callsign**, and enter:
 - *** 3 42993**
 - If the repeater doesn't speak an error, you're connected
 - **Give your ID again**, and make your call or announce you are listening

More User DTMF Commands and Connection Examples

- Example 2:
 - You are on a radio through the 442.275 repeater, node 43078
 - You wish to call another station on the same repeater, and don't want to tie up other systems
 - Key up, **say your callsign**, and enter:
 - * 7 1 which will disconnect ALL linked stations
 - If the repeater doesn't speak an error, you're disconnected
 - Give your ID again, and make your call or announce you are listening
- Example 3:
 - You are on a radio through the 442.275 repeater, node 43078
 - You wish to see what is linked to the 442.275 repeater
 - Key up, **say your callsign**, and enter:
 - * 7 0 which will read back the nodes of everything connected

Still More Examples

- Example 4:
 - You are on a radio through the 442.275 repeater, node 43078
 - You wish to connect to a remote hub node number **27225** , but you don't want to interfere with something on the remote node
 - Key up, **say your callsign**, and enter:
 - *** 2 27225** which will connect in Receive Only mode
 - Transmissions on 442.275 will NOT go to the remote link
 - Activity on the remote link will be heard on 442.275
- Example 5:
 - You initiated a receive only link earlier to node 27225 (above)
 - You wish to initiate transceive mode to talk to the other end
 - Key up, **say your callsign**, and enter:
 - *** 3 27225**
 - Give your callsign again (but don't interrupt remote QSOs)
 - 442.275 is now in full 2 way mode to all systems on the remote hub

Roll Your Own

What does it take to build one of these nodes?

- If you want to do more than use the system, you can build your own!
- Anyone can build an AllStar node
- It's a great learning experience, and useful too!
- You can build:
 - A full fledged repeater
 - A simple low profile repeater out of spare HT's or mobiles
 - A simplex node to access the network easily from your house
- Or you can use your radio and/or computer to use this new system

- Linux Computer (\$29)
 - PC, Laptop
 - Raspberry PI or Beaglebone Black

AND

- Sound card USB dongle
 - Can buy URiX from MRK Engineering (\$69.95)

OR

- Can modify cheap USB sound dongle to add PTT and COS (~ \$15)

- Radio or Repeater

Allstar Hardware

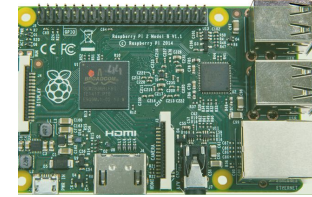

Warning: If you want to make your own repeater - You're going to have to do some Linux

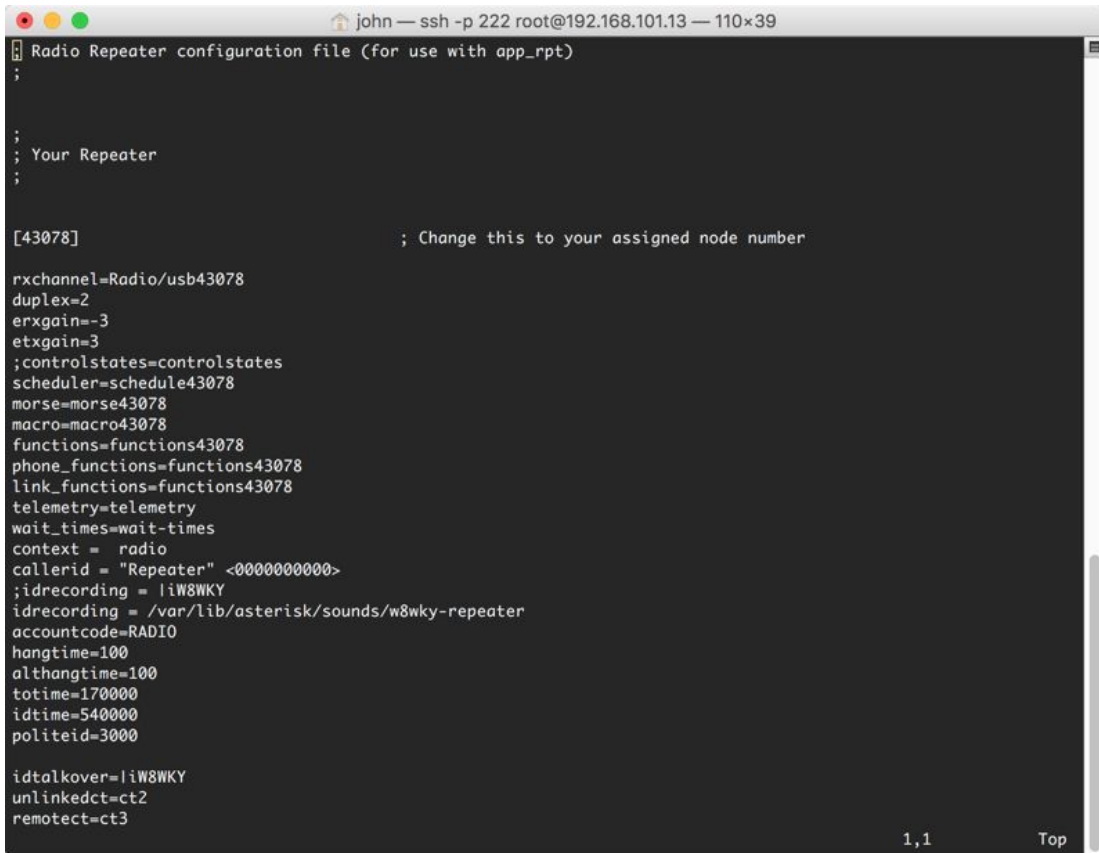

```
john — ssh -p 222 root@192.168.101.13 — 110x39
Radio Repeater configuration file (for use with app_rpt)
;
;
; Your Repeater
;
[43078]                ; Change this to your assigned node number

rxchannel=Radio/usb43078
duplex=2
erxgain=-3
etxgain=3
;controlstates=controlstates
scheduler=schedule43078
morse=morse43078
macro=macro43078
functions=functions43078
phone_functions=functions43078
link_functions=functions43078
telemetry=telemetry
wait_times=wait-times
context = radio
callerid = "Repeater" <0000000000>
;idrecording = liW8WKY
idrecording = /var/lib/asterisk/sounds/w8wky-repeater
accountcode=RADIO
hangtime=100
althangtime=100
totime=170000
idtime=540000
politeid=3000

idtalkover=liW8WKY
unlinkedct=ct2
remotect=ct3

1,1 Top
```

AllStarLink.org makes things easier, but you will need to do some Linux command line to make it all work well